

The distances between the centers of the tetrazole rings of the two molecules forming the 'dimers' are 3.481 Å for (I) and 3.741 Å for (II), indicating fairly strong dipole-dipole interactions. The 'dimers' themselves do not interact strongly with each other as indicated by the distances between tetrazole ring centers of 5.401, 5.902 and 6.694 Å for (I) and 5.863, 6.589 and 8.072 Å for (II). Thus, the forces between 'dimers' are weak and this may account for the large solubilities of (I) and (II).

The distances between the centers of the tetrazole rings of the individual molecules of (III) are 4.390 Å along the 'chains' and 6.132, 6.614 and 7.557 Å to other adjacent molecules. It would be expected that the lattice energy of (III) would be higher (interactions at 4.390 Å between individual molecules) than those of (I) or (II) (interactions at 5.4 Å minimum between 'dimers') and, consequently, the solubility of (III) would be less than that of (I) or (II).

#### References

- BAENZIGER, N. C., NELSON, A. D., TULINSKY, A., BLOOR, J. H. & POPOV, A. I. (1967). *J. Am. Chem. Soc.* **89**, 6463-6465.
- BAUM, R. G. (1976). PhD Thesis, Michigan State Univ., East Lansing, Michigan.
- BODNER, R. L. & POPOV, A. I. (1972). *Inorg. Chem.* **11**, 1410-1414.
- CROMER, D. T. & LIBERMAN, D. (1970). *J. Chem. Phys.* **53**, 1891-1898.
- D'ITRI, F. J. (1968). PhD Thesis, Michigan State Univ., East Lansing, Michigan.
- D'ITRI, F. M. & POPOV, A. I. (1968). *J. Am. Chem. Soc.* **90**, 6476-6481.
- DOYLE, P. A. & TURNER, P. S. (1968). *Acta Cryst.* **A24**, 390-397.
- GERMAIN, G., MAIN, P. & WOOLFSON, M. M. (1971). *Acta Cryst.* **A27**, 368-376.
- HARVILL, E. K., ROBERTS, C. W. & HERBST, R. M. (1950). *J. Org. Chem.* **15**, 58-67.
- JOHNSON, C. K. (1965). *ORTEP*. Report ORNL-3794. Oak Ridge National Laboratory, Oak Ridge, Tennessee.
- KERESZTY & WOLF (1935). German Patent 611,692; *Chem. Abstr.* **29**, 5994-5995.
- KNOLL, A.-G. Chemische Fabriken (1928). German Patent 537,739; *Chem. Abstr.* **26**, 1298.
- POPOV, A. I. & HOLM, R. D. (1962). *J. Phys. Chem.* **66**, 158-160.
- PUTTEN, N. VAN DER, HEIJDENRIJK, D. & SCHENK, H. (1974). *Cryst. Struct. Commun.* **3**, 321-322.
- SMETANA, A. J. (1977). MSc Thesis, Michigan State Univ., East Lansing, Michigan.
- STEWART, R. F., DAVIDSON, E. R. & SIMPSON, W. T. (1965). *J. Chem. Phys.* **42**, 3175-3187.
- STONE, W. E. (1970). *Pharmacology*, **3**, 367-370.
- TEMPLETON, L. K. & TEMPLETON, D. H. (1973). *Abstr. Am. Crystallogr. Assoc. Proc. Ser. 2*, **1**, 143.
- WEI, K.-T. & WARD, D. L. (1976). *Acta Cryst.* **B32**, 2768-2773.
- ZALKIN, A. (1974). Private communication.

*Acta Cryst.* (1979). **B35**, 1419-1424

## The Crystal Structure and the Twinning of $\beta$ -9,10-Dichloroanthracene

BY R. KRAUSS

*Physikalisches Institut, Universität Stuttgart, D-7000 Stuttgart-80, Federal Republic of Germany*

AND HEINZ SCHULZ, R. NESPER AND K. H. THIEMANN

*Max-Planck-Institut für Festkörperforschung, D-7000 Stuttgart-80, Federal Republic of Germany*

(Received 30 August 1978; accepted 12 March 1979)

#### Abstract

$\beta$ -9,10-Dichloroanthracene,  $C_{14}H_8Cl_2$ , crystallizes in the triclinic space group  $P\bar{1}$ . The lattice constants at room temperature are:  $a = 3.873$  (2),  $b = 8.585$  (5),  $c = 16.727$  (7) Å,  $\alpha = 102.38$  (2),  $\beta = 95.30$  (4),  $\gamma = 97.17$  (3)°;  $V = 534.89$  Å<sup>3</sup>,  $D_{\text{calc}} = 1.534$  Mg m<sup>-3</sup>. The unit cell of  $\beta$ -9,10-dichloroanthracene contains two symmetry-independent molecules, each embodying a crystallographic centre of symmetry. The structure can

be described as a stacking of these molecules parallel to the  $a$  axis. The distances between adjacent molecules are 3.48 and 3.52 Å respectively. The structure determination by X-ray diffraction resulted in a final residual  $R = 0.053$  for 1476 observed reflections.  $\beta$ -9,10-Dichloroanthracene crystals exhibit a strong tendency for twinning. The twin law can be described by a twofold rotation around the  $a^*$  axis. The consistency of the twin law with the structure is discussed.

0567-7408/79/061419-06\$01.00

© 1979 International Union of Crystallography

### 1. Introduction

From fluorescence measurements, Kuwano & Kondo (1966) postulated two crystalline forms for 9,10-dichloroanthracene (hereafter 9,10-DCA). They determined lattice constants for both forms, which they designated  $\alpha$ - and  $\beta$ -9,10-DCA. The lattice constants for the former accord with those of Trotter's (1958*a*, 1959) structure analysis of 9,10-DCA. The latter has lattice constants similar to those of 9,10-dibromoanthracene, also studied by Trotter (1958*a,b*).

The existence of  $\alpha$ - and  $\beta$ -9,10-DCA was also confirmed by Tanaka & Shibata (1968) by means of fluorescence and absorption measurements. These authors cite the preliminary results of the structure analysis of  $\beta$ -9,10-DCA by Kuwano & Kondo (1966), showing a projection of the structure down the  $b$  axis. Since the full structure analysis of Kuwano & Kondo (1966) has not been published and the crystal structure was of interest for the analysis of spectroscopic studies in one of our laboratories we have investigated the structure of  $\beta$ -9,10-DCA.

### 2. Experimental details

#### (a) Crystals

Kuwano & Kondo (1966) have reported that the  $\alpha$  form crystallizes from solution, and that the  $\beta$  form can be obtained by heating the  $\alpha$  form above 453 K or directly by sublimation. Our crystals were grown from the melt by the Bridgman method in the Crystal Laboratory of the Institute of Physics at the University of Stuttgart. Prior to growing the crystal, the starting material (K and K Laboratories, Plainview, NY) was zone refined about 100 times.  $\beta$ -9,10-DCA crystals can easily be cleaved in the  $ab$  plane. Because of the strong tendency for twinning the  $b$  axis is easily identified, using a polarizing microscope, as a common axis of two twinned individuals (see § 6).

#### (b) X-ray diffraction

The triclinic symmetry was confirmed by precession and Weissenberg photographs. Cell dimensions and reflection intensities were measured on a Philips PW 1100 single-crystal diffractometer with monochromatic Mo  $K\alpha$  radiation ( $\lambda = 0.7107 \text{ \AA}$ ). For the determination of lattice parameters, 14 sets of reflections, each consisting of 24 reflections, were measured.

Table 1. *Crystal data*

$C_{14}H_8Cl_2, P\bar{1}$	
$a = 3.873 (2) \text{ \AA}$	$\alpha = 102.38 (2)^\circ$
$b = 8.585 (5)$	$\beta = 95.30 (4)$
$c = 16.727 (7)$	$\gamma = 97.17 (3)$
$Z = 2$	$D_{\text{calc}} = 1.534 \text{ Mg m}^{-3}$

The lattice parameters shown in Table 1 are the average over these measurements.

Intensity data were measured in the  $\omega$ -scan mode. 856 reflections of full reciprocal space with  $1^\circ \leq \theta \leq 15^\circ$  and 1647 reflections of a hemisphere in reciprocal space in the region  $14.9^\circ \leq \theta \leq 25^\circ$  were collected. After corrections for Lorentz and polarization effects had been applied, averages were taken over Friedel reflections to give 1882 reflections. 1476 reflections, for which  $I > 3\sigma(I)$ , where  $\sigma(I)$  was calculated from the counting statistics, were considered to be observed.

### 3. Structure determination

A statistical test of the distribution of normalized structure factors gave a strong indication that the structure was centrosymmetric. The initial model was therefore determined in the space group  $P\bar{1}$  by means of direct methods with the program system developed by Sheldrick (1976).

Refinements were carried out with the XRAY 72 program system (Stewart, Kruger, Ammon, Dickinson & Hall, 1972) using the full-matrix least-squares program. The atomic scattering curves were those of Cromer & Mann (1968). All 1476 observed reflections were used in the refinement. The weighting scheme is based on  $\sigma(I)$ . Isotropic refinement resulted in an  $R$  value of 0.175; in the anisotropic refinement  $R$  dropped to 0.053, and  $R_w$  to 0.059.

This large difference was thought to suggest that the structure does not crystallize in  $P\bar{1}$  but rather in  $P1$  and that the false space group might be the cause of the high anisotropy in the temperature factors. The Cl atoms were particularly affected by this; therefore, they were replaced by atoms with partial occupancy for which the longest thermal axis was chosen to be the vector between the sites. If the space group were  $P1$ , one of these sites for each Cl atom should be entirely occupied. This yields two different noncentrosymmetric models which were tested by refinement with isotropic temperature factors. But the refinement of all models yielded final coordinates of a centrosymmetric arrangement. Therefore the final refinement was carried out with space group  $P\bar{1}$ . The H atoms were not included in the structure refinement. Final parameters are listed in Table 2.\*

### 4. Description of structure

The symmetry-unique bond lengths and bond angles of the independent molecules are shown in Figs. 1 and 2.

\* A list of structure factors has been deposited with the British Library Lending Division as Supplementary Publication No. SUP 34333 (20 pp.). Copies may be obtained through The Executive Secretary, International Union of Crystallography, 5 Abbey Square, Chester CH1 2HU, England.

Table 2. *Final atomic parameters*

Positional parameters are expressed as fractions of the cell edges. The units of the anisotropic temperature factors are  $\text{\AA}^2 \times 100$ . The anisotropic temperature factor has been refined in the form

$$T = \exp\left(-2\pi^2 \sum_{i,j}^3 U_{ij} h_i h_j a_i^* a_j^*\right).$$

The standard deviations in units of the last quoted decimal place are enclosed in parentheses.

	<i>x</i>	<i>y</i>	<i>z</i>	<i>U</i> <sub>11</sub>	<i>U</i> <sub>22</sub>	<i>U</i> <sub>33</sub>	<i>U</i> <sub>12</sub>	<i>U</i> <sub>13</sub>	<i>U</i> <sub>23</sub>
C(1)	0.511 (1)	0.3508 (4)	0.4500 (2)	3.7 (2)	3.2 (2)	3.3 (2)	0.7 (2)	0.0 (2)	0.2 (2)
C(2)	0.624 (1)	0.4874 (5)	0.4217 (2)	3.3 (2)	3.7 (2)	3.2 (2)	0.8 (2)	0.0 (2)	0.7 (2)
C(3)	0.750 (1)	0.4789 (5)	0.3430 (2)	4.9 (2)	5.1 (3)	3.6 (2)	1.0 (2)	0.7 (2)	1.3 (2)
C(4)	0.860 (1)	0.6166 (6)	0.3185 (3)	5.0 (3)	6.2 (3)	4.1 (2)	1.0 (2)	0.8 (2)	1.9 (2)
C(5)	0.853 (1)	0.7711 (5)	0.3701 (3)	4.7 (2)	5.0 (3)	5.0 (3)	0.6 (2)	0.4 (2)	2.0 (2)
C(6)	0.732 (1)	0.7842 (5)	0.4454 (3)	4.2 (2)	4.0 (2)	4.7 (2)	0.5 (2)	0.2 (2)	1.7 (2)
C(7)	0.615 (1)	0.6432 (5)	0.4737 (2)	3.5 (2)	3.5 (2)	3.6 (2)	0.7 (2)	0.0 (2)	0.8 (2)
Cl(1)	0.5268 (3)	0.1619 (1)	0.38739 (7)	7.18 (8)	3.25 (6)	4.62 (6)	0.97 (5)	1.05 (5)	-0.29 (4)
C(8)	0.000 (1)	0.8697 (5)	0.9357 (3)	4.9 (2)	4.7 (2)	3.9 (2)	0.1 (2)	1.1 (2)	0.1 (2)
C(9)	0.882 (1)	0.0057 (5)	0.9178 (2)	4.1 (2)	5.3 (3)	3.7 (2)	-0.4 (2)	0.7 (2)	1.1 (2)
C(10)	0.764 (1)	0.0152 (7)	0.8357 (3)	5.5 (3)	8.4 (4)	4.7 (3)	-0.5 (3)	0.1 (2)	2.8 (3)
C(11)	0.650 (1)	0.1516 (8)	0.8210 (4)	5.6 (3)	10.5 (5)	6.8 (4)	-0.3 (3)	0.4 (3)	4.5 (4)
C(12)	0.644 (1)	0.2867 (8)	0.8860 (4)	5.5 (3)	8.6 (4)	9.6 (4)	0.6 (3)	1.2 (3)	5.7 (4)
C(13)	0.757 (1)	0.2840 (6)	0.9669 (4)	5.2 (3)	5.8 (3)	8.3 (4)	0.6 (2)	1.8 (3)	2.9 (3)
C(14)	0.880 (1)	0.1426 (5)	0.9847 (3)	4.1 (2)	4.8 (2)	4.7 (2)	0.2 (2)	1.2 (2)	1.4 (2)
Cl(2)	0.0040 (4)	0.7042 (2)	0.8550 (1)	10.3 (1)	6.3 (1)	5.6 (1)	0.6 (1)	2.2 (1)	-1.3 (1)

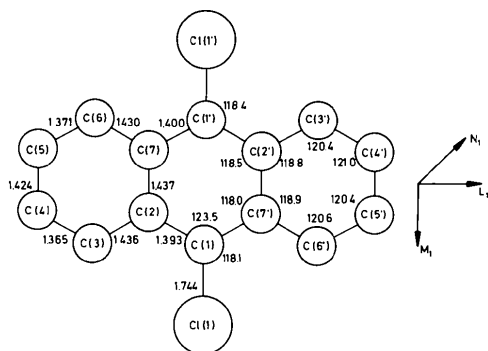

Fig. 1. Bond lengths ( $\text{\AA}$ ) and bond angles ( $^\circ$ ) of molecule 1. Small and large circles refer to C and Cl atoms respectively. The numbers refer to the atom designation of Table 2. The standard deviations are less than  $0.007 \text{\AA}$  for the bond lengths and less than  $0.5^\circ$  for the angles.  $L_1$  and  $M_1$ , respectively, designate the long and short axes of molecule 1.  $N_1$  is the normal on the molecular plane.

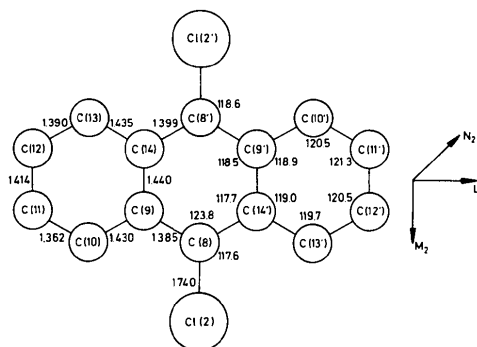

Fig. 2. Bond lengths ( $\text{\AA}$ ) and bond angles ( $^\circ$ ) of molecule 2. The standard deviations are less than  $0.009 \text{\AA}$  for the bond lengths and less than  $0.6^\circ$  for the angles. For details see caption to Fig. 1.

A plane can be defined for each molecule in the form  $lX + mY + nZ + p = 0$ , where  $X, Y, Z$  are coordinates of a point in the plane expressed in  $\text{\AA}$  and referred to the triclinic crystal axes. If the planes of the molecules are taken through the Cl atoms and the midpoints of the bonds C(4)–C(5) or C(11)–C(12), respectively, the equations of these planes are: molecule 1:  $0.8997X - 0.1957Y + 0.3512Z - 3.8397 = 0$ ; molecule 2:  $0.9092X + 0.2825Y - 0.2901Z - 1.0951 = 0$ . No atom deviates significantly from these mean planes. A system of molecular axes is useful for the description of the structure and the following calculations: We

designate the normals of the molecules as  $\mathbf{N}$  and the vectors connecting the chlorine atoms, Cl(1')–Cl(1) and Cl(2')–Cl(2), respectively, as  $\mathbf{M}$ .  $\mathbf{L}$  is taken perpendicular to the  $\mathbf{M}$  and  $\mathbf{N}$  vectors.

The perpendicular distance between the planes of molecules related by the translation  $\mathbf{a}$  is  $3.48 \text{\AA}$  for molecule 1 and  $3.52 \text{\AA}$  for molecule 2. In Fig. 3(a) and (b), two adjacent molecules are projected along the normals  $N_1$  and  $N_2$  respectively. The figures illustrate the displacements  $\Delta x$ ,  $\Delta y$  of the molecules from each other in terms of the molecular coordinate system. The projections of the molecules along  $\mathbf{a}$ ,  $\mathbf{b}$ , and  $\mathbf{c}$  are shown in Fig. 4(a)–(c). These demonstrate that the inequivalent molecules build two inequivalent stacks along the short axis  $a$ .

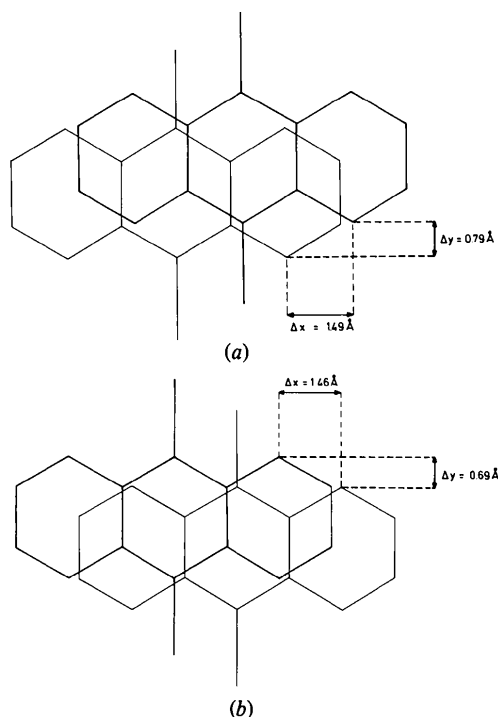

Fig. 3. Projection of two neighbouring molecules along the normals  $N$ . The figure demonstrates the displacements  $\Delta x$  and  $\Delta y$  of the molecules with respect to each other in the coordinate system  $L, M, N$ . (a) Molecules 1 along  $N_1$  (cf. Fig. 1), interplanar distance 3.48 Å. (b) Molecules 2 along  $N_2$  (cf. Fig. 2), interplanar distance 3.52 Å.

### 5. Similarity of different unit cells

It is possible to choose different unit cells for  $\beta$ -9,10-DCA, *i.e.* different lattice vectors  $\mathbf{a}, \mathbf{b}, \mathbf{c}$  which yield very similar lattice constants  $a, b, c, \alpha, \beta, \gamma$ . The lattice vectors and the corresponding lattice constants used in the previous sections are labelled with subscript 1; other similar systems are subscripted with the indices 2–4. To describe the relationships of cells 2–4 to 1 we present the appropriate transformation matrices. The transformation

$$\begin{pmatrix} \mathbf{a}_2 \\ \mathbf{b}_2 \\ \mathbf{c}_2 \end{pmatrix} = \begin{pmatrix} 1 & 0 & 0 \\ 0 & 1 & 0 \\ -1 & -1 & -1 \end{pmatrix} \begin{pmatrix} \mathbf{a}_1 \\ \mathbf{b}_1 \\ \mathbf{c}_1 \end{pmatrix}$$

converts the cell used in this work (1) to another (2) with almost identical dimensions:

$$\begin{aligned} a_2 &= 3.87 \text{ \AA} & b_2 &= 8.58 \text{ \AA} & c_2 &= 16.93 \text{ \AA} \\ \alpha_2 &= 105.45^\circ & \beta_2 &= 94.24^\circ & \gamma_2 &= 97.17^\circ. \end{aligned}$$

The lattice system  $\mathbf{a}_2, \mathbf{b}_2, \mathbf{c}_2$  appears to be that reported by Kuwano & Kondo (1966).

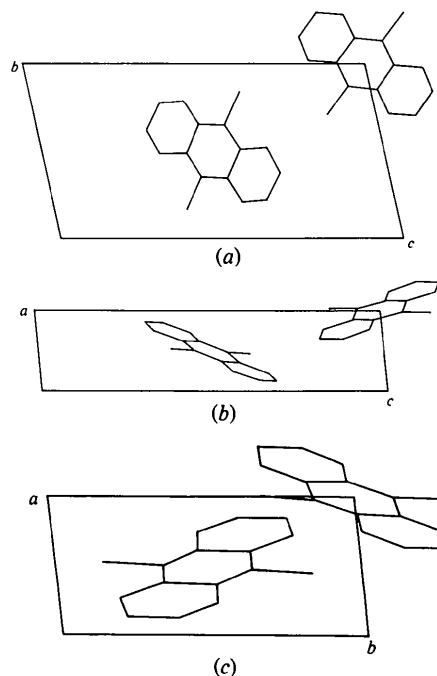

Fig. 4. Projection of the structure (a) on to (100) viewed along  $[100]$ , (b) on to (010) viewed along  $[010]$  and (c) on to (001) viewed along  $[001]$ .

One obtains, by two further transformations, unit cells with lattice constants similar to  $a_1, b_1, c_1$ . These transformations, however, do not yield cells with three obtuse angles.

$$\begin{pmatrix} \mathbf{a}_3 \\ \mathbf{b}_3 \\ \mathbf{c}_3 \end{pmatrix} = \begin{pmatrix} 1 & 0 & 0 \\ 0 & 1 & 0 \\ 0 & 1 & 1 \end{pmatrix} \begin{pmatrix} \mathbf{a}_1 \\ \mathbf{b}_1 \\ \mathbf{c}_1 \end{pmatrix}$$

$$\begin{aligned} a_3 &= 3.87 \text{ \AA} & b_3 &= 8.58 \text{ \AA} & c_3 &= 17.09 \text{ \AA} \\ \alpha_3 &= 73.01^\circ & \beta_3 &= 98.81^\circ & \gamma_3 &= 97.17^\circ. \end{aligned}$$

$$\begin{pmatrix} \mathbf{a}_4 \\ \mathbf{b}_4 \\ \mathbf{c}_4 \end{pmatrix} = \begin{pmatrix} 1 & 0 & 0 \\ 0 & 1 & 0 \\ 1 & 0 & 1 \end{pmatrix} \begin{pmatrix} \mathbf{a}_1 \\ \mathbf{b}_1 \\ \mathbf{c}_1 \end{pmatrix}$$

$$\begin{aligned} a_4 &= 3.87 \text{ \AA} & b_4 &= 8.58 \text{ \AA} & c_4 &= 16.82 \text{ \AA} \\ \alpha_4 &= 104.00^\circ & \beta_4 &= 82.06^\circ & \gamma_4 &= 97.17^\circ. \end{aligned}$$

### 6. The twin law

We often observed twinned crystals when the dimension in the  $\mathbf{a}$  direction exceeded *ca* 0.5 mm.

Observations with a polarizing microscope are consistent with twinning occurring along macroscopic

common faces which run parallel to a common  $b$  axis as identified by oscillation photographs. In the orientation procedure on the diffractometer a twinned crystal was identified when a series of reflections could not be indexed with integral indices on the basis of the orientation matrix **UB 1** of the individual 1. With these reflections and repetition of the orientation procedure, all of these reflections could be appropriately indexed starting from the orientation matrix **UB 1'** of an individual 1'. The orientation matrix describes the reciprocal-lattice vectors in the coordinate system of the diffractometer. The columns of the orientation matrix are the projections of  $\mathbf{a}^*$ ,  $\mathbf{b}^*$ ,  $\mathbf{c}^*$  on the axes of this coordinate system.

The twin law can be derived from a comparison of the orientation matrix **UB 1** with **UB 1'**. Care must be taken to consider that the orientation matrices of the twin individuals can be based on different systems  $a, b, c, \alpha, \beta, \gamma$ .

We investigated the twin law for two twinned crystals. For one of these crystals the orientation for individual 1 is represented by

$$\mathbf{UB 1} = \begin{pmatrix} 0.020244 & 0.083894 & 0.018312 \\ -0.018056 & 0.016858 & -0.039814 \\ 0.184077 & 0.005374 & -0.000382 \end{pmatrix}$$

with the lattice constants

$$a_1 = 3.880 \text{ \AA} \quad b_1 = 8.584 \text{ \AA} \quad c_1 = 16.736 \text{ \AA} \\ \alpha_1 = 102.421^\circ \quad \beta_1 = 95.407^\circ \quad \gamma_1 = 97.179^\circ.$$

The orientation of individual 1' is given by

$$\mathbf{UB 1'} = \begin{pmatrix} 0.020253 & -0.081054 & -0.017206 \\ -0.017510 & -0.019363 & 0.038806 \\ 0.183447 & 0.018793 & 0.010632 \end{pmatrix}$$

**UB 1'** is based on the lattice system with constants

$$a_1' = 3.883 \text{ \AA} \quad b_1' = 8.595 \text{ \AA} \quad c_1' = 16.732 \text{ \AA} \\ \alpha_1' = 102.324^\circ \quad \beta_1' = 94.942^\circ \quad \gamma_1' = 96.513^\circ.$$

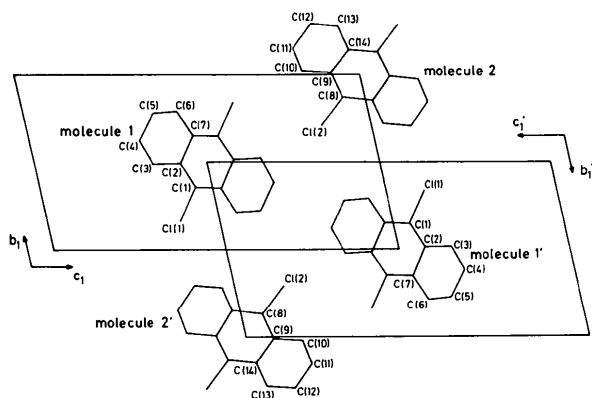

Fig. 5. The mutual positions of the two individuals in a twin. For details see caption to Fig. 4(a).

Concerning the accuracy of the lattice parameters which are derived from a small number of reflections (**UB 1** with 20 and **UB 1'** with 5), the orientation matrices **UB 1** and **UB 1'** are described in the same lattice system subscripted by 1 (cf. § 5). Comparison of **UB 1** with **UB 1'** shows that  $\mathbf{a}_1^* = \mathbf{a}_1'^*$ . According to the relations  $\mathbf{b} = (\mathbf{c}^* \times \mathbf{a}^*)/V^*$  and  $\mathbf{c} = (\mathbf{a}^* \times \mathbf{b}^*)/V^*$  we find also that  $\mathbf{b}_1 = -\mathbf{b}_1'$  and  $\mathbf{c}_1 = -\mathbf{c}_1'$ .

Hence the twin law takes its simplest form in the lattice system  $\mathbf{a}_1, \mathbf{b}_1, \mathbf{c}_1$ . Summarizing, one can write:  $\mathbf{a}_1^* = \mathbf{a}_1'^*$  and simultaneously  $\mathbf{b}_1 = -\mathbf{b}_1'$  and  $\mathbf{c}_1 = -\mathbf{c}_1'$ .

The symmetry element which describes the twin formation and which is not a symmetry operator in space group  $P\bar{1}$  is a twofold rotation around the  $\mathbf{a}^*$  axis. In consideration of the centrosymmetric structure this corresponds to a (100) mirror plane in direct space.

An important consequence of this twin law is that a macroscopic twinned crystal of  $\beta$ -9,10-DCA consists of only two types of individuals oriented differently in space.

The twinning is also consistent with the structure. We display the relative arrangement of the molecules at the twin boundaries in Fig. 5. Individual 1' is created from individual 1 in two steps: (1) rotation around the twofold twin axis coincident with  $\mathbf{a}^*$  and (2) translation of the molecules generated along  $0.5(\mathbf{a} + \mathbf{b} + \mathbf{c})$ .

Fig. 5 illustrates that, in a twinned crystal, the linear stack of molecules 1 along  $\mathbf{a}$  abuts the stack of molecules 2' of the second twin member at the common  $bc$  face, and *vice versa*. The orientation of adjacent molecules of the respective individuals differs only by a slight tilt of the molecules' plane normals  $N$  and by a somewhat larger rotation of the short and long in-plane molecular axes  $M$  and  $L$ . To describe this quantitatively one should use a suitable Cartesian coordinate system for the molecular axes, for which we select the system  $\mathbf{a}_1^*, \mathbf{b}_1, \mathbf{a}_1^* \times \mathbf{b}_1$ . The direction cosines of the molecular axes of individual 1 with respect to the axes of this system are shown in Table 3.

The same calculations can be performed for individual 1'. The description of the molecular axes  $L_1', M_1', N_1'$  and  $L_2', M_2', N_2'$  of the molecules of individual 1'

Table 3. Direction cosines between the molecular axes  $L, M, N$  of the individual 1 and  $\mathbf{a}_1^*, \mathbf{b}_1, \mathbf{a}_1^* \times \mathbf{b}_1$

Molecule 1			
	$\mathbf{a}_1^*$	$\mathbf{b}_1$	$\mathbf{a}_1^* \times \mathbf{b}_1$
$L_1$	-0.370781	-0.560943	0.740179
$M_1$	0.032763	-0.804392	-0.593195
$N_1$	0.928142	-0.195695	0.316633
Molecule 2			
	$\mathbf{a}_1^*$	$\mathbf{b}_1$	$\mathbf{a}_1^* \times \mathbf{b}_1$
$L_2$	0.367428	-0.706595	0.604747
$M_2$	0.004860	-0.648763	-0.760975
$N_2$	0.930039	0.282542	-0.234940

in the coordinate system  $\mathbf{a}_1^*$ ,  $\mathbf{b}_1^*$ ,  $\mathbf{a}_1^* \times \mathbf{b}_1^*$  of individual 1' simply reproduces the values in Table 3. Obviously, to establish the relations between the molecules in the twinned individuals these molecules must be described in a single coordinate system.

We interpret the direction cosines of the molecular axes  $L$ ,  $M$ ,  $N$  and  $L'$ ,  $M'$ ,  $N'$  in the coordinate systems  $\mathbf{a}_1^*$ ,  $\mathbf{b}_1^*$ ,  $\mathbf{a}_1^* \times \mathbf{b}_1^*$  and  $\mathbf{a}_1^{*'}$ ,  $\mathbf{b}_1^{*'}$ ,  $\mathbf{a}_1^{*' \times} \mathbf{b}_1^{*'}$ , respectively, as the vector components of  $\mathbf{L}$ ,  $\mathbf{M}$ ,  $\mathbf{N}$  and  $\mathbf{L}'$ ,  $\mathbf{M}'$ ,  $\mathbf{N}'$  in these systems.

Since the vectors in the Cartesian system transform in the same manner as their coordinates, we find the transformation matrices from the twin law:

$$\begin{pmatrix} \mathbf{a}_1^{*' \\ \mathbf{b}_1^{*' \\ \mathbf{a}_1^{*' \times} \mathbf{b}_1^{*' \end{pmatrix} = \begin{pmatrix} 1 & 0 & 0 \\ 0 & -1 & 0 \\ 0 & 0 & -1 \end{pmatrix} \begin{pmatrix} \mathbf{a}_1^* \\ \mathbf{b}_1^* \\ \mathbf{a}_1^* \times \mathbf{b}_1^* \end{pmatrix}$$

and the inverse

$$\begin{pmatrix} \mathbf{a}_1^* \\ \mathbf{b}_1^* \\ \mathbf{a}_1^* \times \mathbf{b}_1^* \end{pmatrix} = \begin{pmatrix} 1 & 0 & 0 \\ 0 & -1 & 0 \\ 0 & 0 & -1 \end{pmatrix} \begin{pmatrix} \mathbf{a}_1^{*' \\ \mathbf{b}_1^{*' \\ \mathbf{a}_1^{*' \times} \mathbf{b}_1^{*' \end{pmatrix}.$$

With these transformation matrices it is possible to describe the orientation of  $L'$ ,  $M'$ ,  $N'$  in the system  $\mathbf{a}_1^*$ ,  $\mathbf{b}_1^*$ ,  $\mathbf{a}_1^* \times \mathbf{b}_1^*$  (Table 4).

Comparison of Table 3 with Table 4 gives the angles between the axes  $L$ ,  $M$ ,  $N$  in individual 1 and the axes  $L'$ ,  $M'$ ,  $N'$  in individual 1':

$$\angle(L_1, L_2') = \angle(L_1', L_2) = 11.42^\circ$$

$$\angle(M_1, M_2') = \angle(M_1', M_2) = 13.32^\circ$$

$$\angle(N_1, N_2') = \angle(N_1', N_2) = 6.84^\circ.$$

Hence the planes of adjacent molecules from twinned individuals are parallel up to  $6.84^\circ$ , and their short and long axes intersect at angles of  $13.32^\circ$  and  $11.42^\circ$  respectively.

The authors wish to thank Dr W. Denner from the MPI for his assistance in deriving the twin law. We also express our thanks to Dr N. Karl from the Kristallabor

Table 4. *Direction cosines between the molecular axes  $L'$ ,  $M'$ ,  $N'$  of individual 1' and  $\mathbf{a}_1^*$ ,  $\mathbf{b}_1^*$ ,  $\mathbf{a}_1^* \times \mathbf{b}_1^*$  of individual 1*

Molecule 1'			
	$\mathbf{a}_1^*$	$\mathbf{b}_1^*$	$\mathbf{a}_1^* \times \mathbf{b}_1^*$
$L_1'$	-0.370781	0.560943	-0.740179
$M_1'$	0.032763	0.804392	0.593195
$N_1'$	0.928142	0.195695	-0.316633
Molecule 2'			
	$\mathbf{a}_1^*$	$\mathbf{b}_1^*$	$\mathbf{a}_1^* \times \mathbf{b}_1^*$
$L_2'$	0.367428	0.706595	-0.604747
$M_2'$	0.004860	0.648763	0.760975
$N_2'$	0.930039	-0.282542	0.234940

der Universität Stuttgart for supplying us with the crystals. The stimulating interest of Professor Dr D. Schmid from the Universität Stuttgart is gratefully acknowledged.

We are indebted to Dr J. Stezowski from the Universität Stuttgart for his careful inspection of the manuscript. The support by the Deutsche Forschungsgemeinschaft for one of us (RK) is also acknowledged.

#### References

- CROMER, D. T. & MANN, J. B. (1968). *Acta Cryst.* **A24**, 321-324.  
 KUWANO, H. & KONDO, M. (1966). *Bull. Chem. Soc. Jpn*, **39**, 2779-2780.  
 SHELDRIK, G. M. (1976). *SHELX*. A program system for structure determination. Cambridge Univ.  
 STEWART, J. M., KRUGER, G. J., AMMON, H. L., DICKINSON, C. & HALL, S. R. (1972). The XRAY system - version of June 1972. Tech. Rep. TR-192. Computer Science Center, Univ. of Maryland, College Park, Maryland.  
 TANAKA, J. & SHIBATA, M. (1968). *Bull. Chem. Soc. Jpn*, **41**, 34-41.  
 TROTTER, J. (1958a). *Acta Cryst.* **11**, 564.  
 TROTTER, J. (1958b). *Acta Cryst.* **11**, 803-807.  
 TROTTER, J. (1959). *Acta Cryst.* **12**, 54-58.